

A PowerPhysics White Paper

ONE-CYCLE SOUND™ AUDIO AMPLIFIERS

The switching amplifier is poised to become the dominant technology in the public address and sound reinforcement market. PowerPhysics' One-Cycle Sound control method and circuit topologies combined with modern semiconductor devices give our switching audio amplifier products size, cost, and performance improvements compared to other technologies available in the industry. Our switching amplifier has an electrical efficiency near 96 percent so it generates much less heat than linear amplifiers, allowing lower cost, smaller, and lighter systems to be built. New soft switching circuit topologies and improved power metal-oxide semiconductor field-effect transistors (MOSFETs) allow higher switching frequencies, a requirement for low distortion pulse width modulation (PWM). Our proprietary One-Cycle Sound control technique will drive errors to zero within one switching cycle, further ensuring high fidelity audio amplification with simple circuitry. Our amplifiers achieve THD+N distortion levels below .07% over 20-20Khz and up to full power. We have demonstrated this control technique with prototype and production units at maximum power levels of 100, 200, and 500W into 8 ohms and 200, 400, and 1000 watts into 4 ohms.

PowerPhysics has developed amplifiers based on protected intellectual property that will out perform the competition pound for pound and dollar for dollar. After a brief introduction to switching (Class D) amplifiers is given, this paper describes how the simple One-Cycle Sound PowerPhysics control method achieves such low distortion. Then the experimental frequency response, THD+N and power supply ripple rejection (PSRR) for a 100w 20-20kHz bandwidth amplifier are given to prove the control performance.

SO WHAT IS SPECIAL ABOUT A SWITCHING AMPLIFIER?

Switching amplifiers (Class D) are significantly more efficient than their linear amplifier counterparts (Class A, Class AB, Class G). Switching amplifiers, like the simplifier circuit shown in figure 1, use semiconductor devices as switches (i.e. S1, S2, S3, and S4) along with a

variety of other elements (capacitors, inductors, and small transformers) to amplify the signal at the speaker. Since the semiconductor devices are used as on-off switches, theoretically 100 percent efficiency can be achieved. When a switch is on, it is essentially a short circuit. Although high current may pass through the switch, since the voltage across the switch is very small, little energy is lost. When the switch is off, no current flows, so the energy loss is zero. Traditional linear amplifiers use transistors that operate in the linear region where both large voltage and current are imposed across the device. Therefore, while current is flowing through the device, the power lost in the transistor is very large and requires a large heat sink. At full output power (0db), the Class AB linear amplifier theoretically reaches 80 percent efficiency, but its efficiency drops below 10 percent with over 90 percent of the power wasted as heat when the output is reduced to normal listening levels (-24db). Other types of linear amplifiers have even lower efficiency. For switching amplifiers close to 100 percent efficiency can be achieved regardless of the power level.

Operating with high efficiency lowers the amplifier's production costs by decreasing its size and weight and increases reliability by lowering the semiconductor's junction temperature. Energy lost in an amplifier is converted into heat. To ensure the circuit devices and systems do not overheat and fail thermal management components like fans and heat sinks must be added. The more energy that is wasted as heat, the larger and more expensive the thermal management techniques employed. This increases the size, weight, complexity and ultimately the cost of the system. Since PowerPhysics amplifiers are so efficient, our amplifiers do not require a fan to get long lasting pounding sound in the most extreme environments.

HOW CAN YOU CONTROL THIS SWITCHING AMPLIFIER?

Ordinary PWM methods with high switching frequencies will not produce high fidelity amplification. High fidelity audio amplification requires a wide bandwidth and low distortion. These requirements challenge the conventional

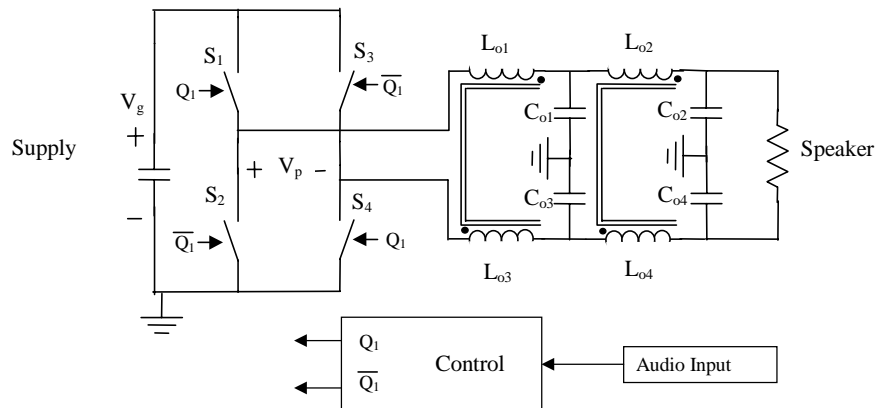

Figure 1. Simplified diagram of a PowerPhysics Amplifier.

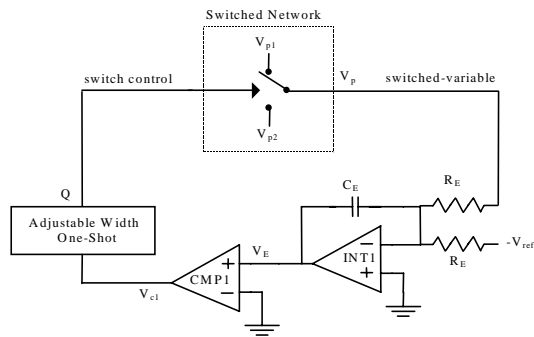

Figure 1. Conceptual diagram of the new control method.

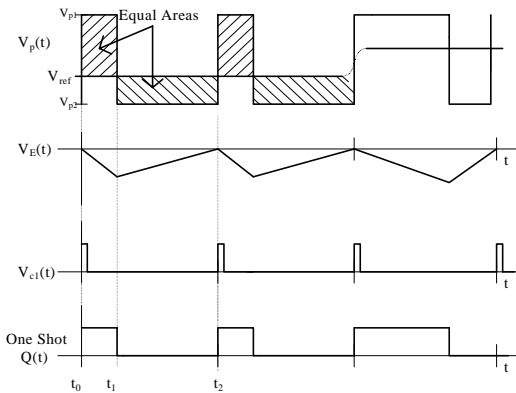

Figure 2. Timing diagram of the new control method.

PWM method and linear control and require the use of the new non-linear control invented by Dr. Smith of PowerPhysics (U.S. patent 6084450). The non-linear control method invented by Dr. Smith et. al. monitors the switched variable on a cycle-by-cycle basis and is the reason PowerPhysics has termed this One-Cycle Sound. This method can ensure that in each cycle the average value of the output (speaker powers) equals the control reference (audio signal), thereby inherently rejecting power supply disturbances and non-ideal switching edges. This dramatically lowers the power source regulation requirements and easily allows increased efficiency via soft switching.

The goal of any audio amplifier control method is to ensure that the output voltage equals the amplified value of the input audio signal. Any difference between these signals is an error that must be corrected by the control method. The longer it takes the control system to correct errors the greater the distortion in the output. Therefore, it is imperative that the errors are corrected as quickly as possible. In a switching amplifier the best possible performance is achieved when the error is zero at the end of the switching cycle. Because our switching amplifiers switch at 250kHz and higher rate, they are correcting for errors almost instantly. Linear feedback techniques are hampered by this switching frequency and can only achieve bandwidths as high as 40kHz-60Khz range with a 250Khz

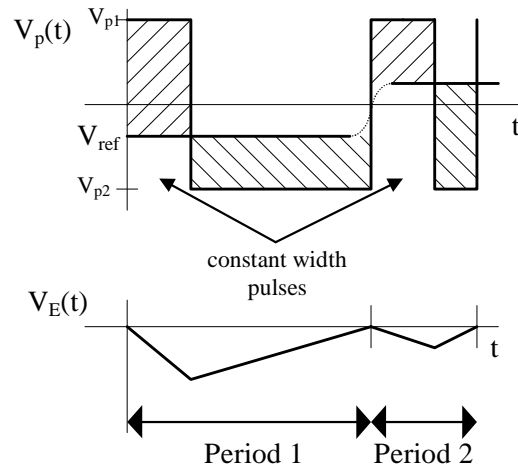

Figure 3. Constant one-shot pulse width.

frequency switching, equating to a much longer delay before the error is corrected for.

The PowerPhysics One-Cycle Sound control method achieves the optimal performance by guaranteeing the error is zero each cycle. To illustrate, Figure 1 shows the conceptual diagram of the new control method and Figure 2 shows the theoretical waveforms. The switched network represents any system where a switched-variable V_p is to be controlled. For example, as shown in figure 1, the switched-variable of an H-Bridge converter is the voltage between each half bridge. When switch S1 and S4 are on, V_p equals $+V_g$. When switch S2 and S3 are on, V_p equals $-V_g$. The one cycle response of the system is ensured by integrator INT1 which forces the local average (average over one switching cycle) of the switched-variable, $\langle V_p \rangle$ to exactly equal V_{ref} each switching cycle. The width of the *one-shot* is adjusted each cycle to achieve constant switching frequency. A switching cycle starts at t_0 with the one-shot being triggered by a pulse from comparator CMP1. This forces V_p to equal the upper rail (V_{p1}) and the error integrator will integrate the difference between V_{p1} and V_{ref} until the end of the one shot pulse at t_1 . The switch then changes its state and causes V_p to equal the lower rail (V_{p2}) and the error integrator will integrate the difference between V_{p2} and V_{ref} until the error equals zero at t_2 , assuming $V_{p1} > V_{p2}$. Then CMP1 triggers another one shot and the next cycle is started. Notice that the shaded areas are equal, proving that the local average $\langle V_p \rangle$ exactly equals V_{ref} at the end of the switching cycle and one cycle response will be performed. The switching frequency is held nearly constant by adjusting the width of the one-shot pulse to account for changes in V_{p1} , V_{p2} , and V_{ref} . By taking advantage of the non-linear nature of switching amplifiers both optimal control and simple implementation are realized by the PowerPhysics One-Cycle Sound control method invented by Dr. Smith et. al.

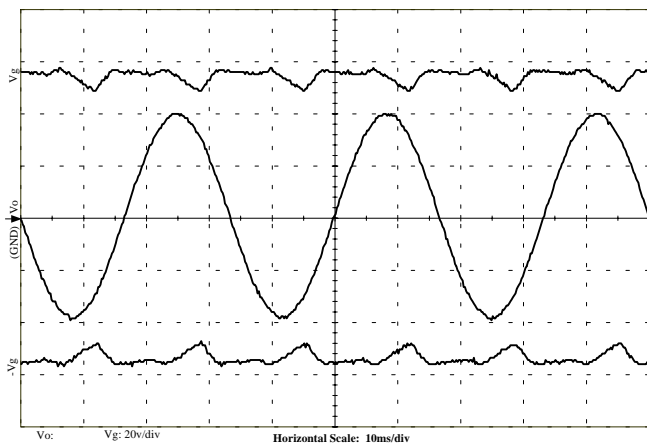

Figure 6. Time domain ripple rejection.

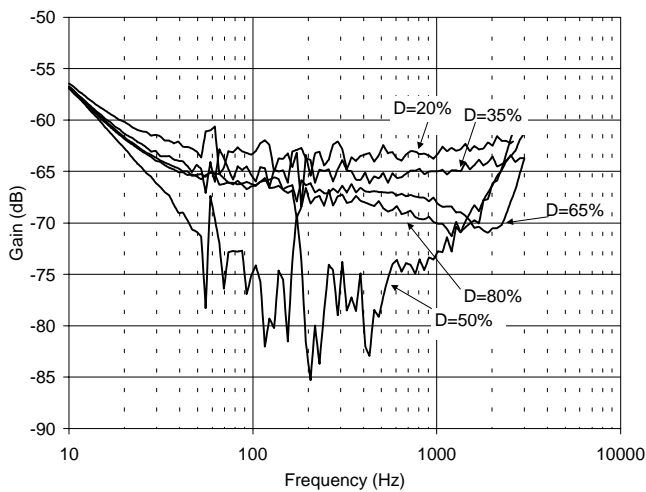

Figure 7. Power supply ripple rejection for a DC output.

AUDIO AMPLIFIER PERFORMANCE RESULTS

The results of our 95 watt RMS, 0-20Khz bandwidth audio amplifier are given to prove the theoretical expectation of the control method performance. The power supply for the bus voltage, V_g , is a bridge rectifier from the AC mains and was used for all experiments except for the ripple rejection vs. frequency test where a swept sinusoidal source is required. The average V_g voltage is 54 volts at full output power. The nominal switching frequency is 250kHz and the load, R_o , is an 8 Ohm resistor.

Power Supply Ripple Rejection (PSRR)

One of the unique characteristics of One-Cycle Sound, is its ability to reject large signal power supply ripple. This significantly lowers the regulation requirement of the V_g source. In the experimental system, a bridge rectifier with a small capacitor filter was used. The ripple on the power supply was 8 volts at full power (15% of the average 54 volts). Figure 6 shows a time domain waveform of the ripple rejection capability of the system. Even with this 15% power supply (V_g) ripple, the output voltage (V_o) shows no effect. The inverse of V_g , $-V_g$, is also shown to give a

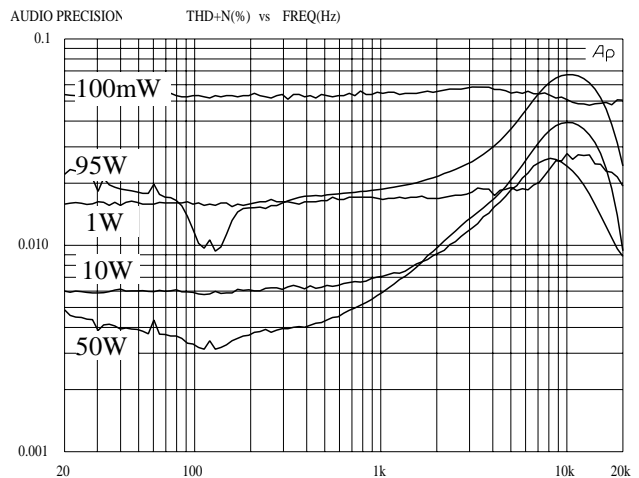

Figure 4. THD + N vs. frequency.

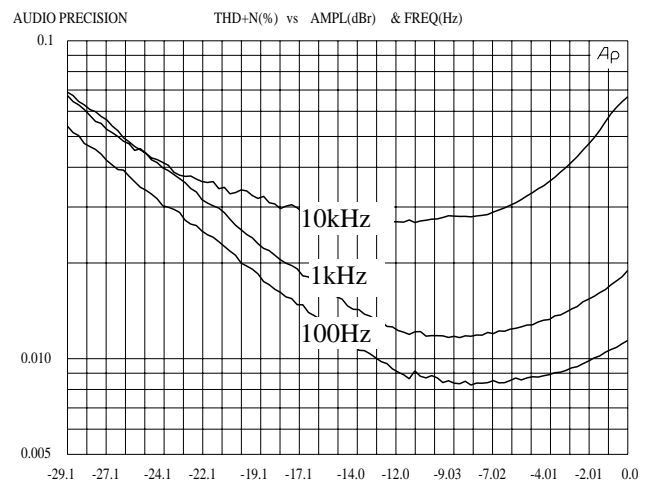

Figure 5. THD + N vs. amplitude relative to maximum output voltage.

bottom reference for the negative output voltage, but there is only one power source. To further quantify the ripple rejection ability of the system, the PSRR test was performed by inducing an intentional ripple in the power supply of 20% ($V_g = 45 + 4.5\sin(\omega_g t)$). The frequency of the ripple was then swept and the gain of the power supply ripple to output is shown in Figure 7 for different DC V_{ref} signals represented by duty ratio. This figure shows the excellent power supply ripple rejection One-Cycle Sound control method obtains. Low frequency noise is attributed to the slight rise in rejection below 60Hz. At 120Hz, the fundamental of an AC-DC rectifier, the worst case rejection is more than 63dB when the amplifier has is outputting a DC signal of 60Watts. However, music is not DC, but centers around zero volts (i.e. 50% duty ratio). For audio amplification the ripple rejection is better than 80dB.

Harmonic Distortion

An Audio Precision System One instrument was used to test the THD+N and the CCIF intermodulation distortion. For the THD+N tests, the upper bandwidth of the System One input filter was set to 80kHz. For the CCIF

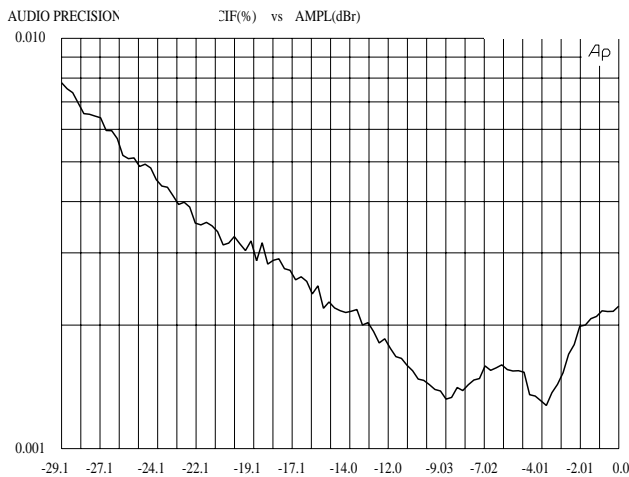

Figure 8. CCIF intermodulation distortion vs. output level with tones at 19kHz and 20kHz.

intermodulation distortion tests, two tones at 19k and 20k were set and the distortion component at 1kHz was measured versus output power.

The THD+N response of the amplifier is shown in Figure 4 for different values of output power. Even with an unregulated power supply, V_g , with a 15% ripple, the results show less than 0.07% THD+N over the complete frequency range. Figure 5 shows similar results for THD+N vs. amplitude for several frequencies. The amplitude is relative to the full power output voltage (-29.1dB corresponds to 100mWatt).

The CCIF response is shown in Figure 8 where the output level is relative to the output at full power. The distortion level is less than .008%.

Frequency Response

Using an Audio Precision System One Instrument, the large signal frequency response of the experimental audio amplifier normalized frequency response V_{ref} was measured and shown in Figure 9, where the magnitude is relative to the full power output voltage.

SUMMARY

The patented PowerPhysics One-Cycle Sound control technique was presented. The low distortion levels, excellent PSRR results, and simplicity of construction make this method exceptionally suited for control of demanding switching audio amplifier applications. The THD+N distortion level achieved with this equal or better high

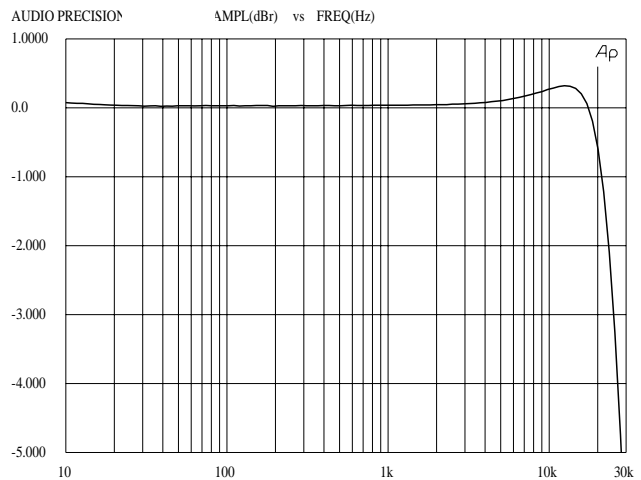

Figure 9. Transfer frequency response of audio amplifier.

fidelity linear audio amplifiers. Since the power semiconductors are operating in PWM mode, much higher efficiency (thus smaller size) can be obtained. Because the method ensures that the error between the reference and the switching variable is zero each cycle, it rejects power supply disturbances. Therefore, the bus voltage for the full bridge needs little or no regulation. This same characteristic also allows switch asymmetries and non-ideal switching edges. Consequently, the switches do not have to be matched with zero effect on the performance levels. Since the control strategy has inherent feedforward and feedback properties without a physical dynamic feedback loop, stability is guaranteed.

The results from a 95 Watt RMS power and 0-20Khz bandwidth full bridge amplifier were given to demonstrate the applicability of the control to high fidelity audio applications. The results show THD+N levels below .07%, CCIF inter-modulation distortion below .008%, and PSRR levels greater than 80dB at 120Hz. PowerPhysics produces a complete line of One-Cycle Sound amplifier modules ranging from 100W to 1000W.

For additional information please contact Dr. K. M. Smith at:

PowerPhysics
 877 Production Place
 Newport Beach, CA 92663-2809
 949.515.6202
 msmith@powerphysics.com