

## Features

- Two Channel Amplifier 2x150 watts
- Bridged Power: 500W
- Proprietary “One Cycle Sound” Control
- 117dBA dynamic Range
- THD+N < 0.05%, 0.1W – Rated Power
- Amplifier Efficiency > 95%
- Damping Factor > 375@ 100Hz 4 Ohms
- DC offset < 25mV
- Remote Disable
- Over Current Clamp for low Z loads.
- Over Current Protection to Output Short.
- Output current monitor.
- Click-less Turn-on
- Temperature Monitor and Fold back
- Synchronized Switching Frequencies.
- External frequency Sync Capable
- Power Supply Under Voltage Lockout

## Product Description:

Based on the PowerPhysics proprietary “One Cycle Sound” control method, the A2-154 provides Two channels of 150 Watts of pristine audio into 4 ohm speakers. Bridging the two channels provides 500watts into 4 ohms. Outputs include temperature and current monitoring ideally suited for off board analysis. The amplifiers are fully protected against any type of thermal overload, output short or speaker fault to provide robust, long term operation.

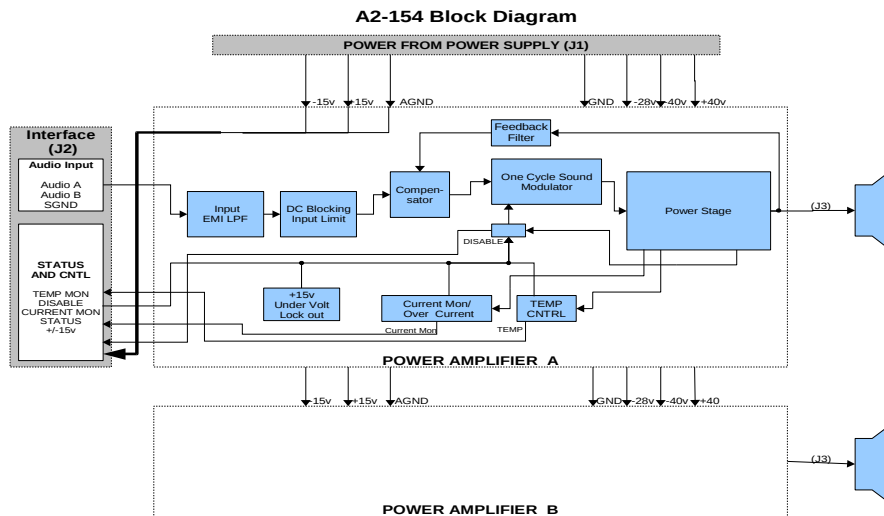

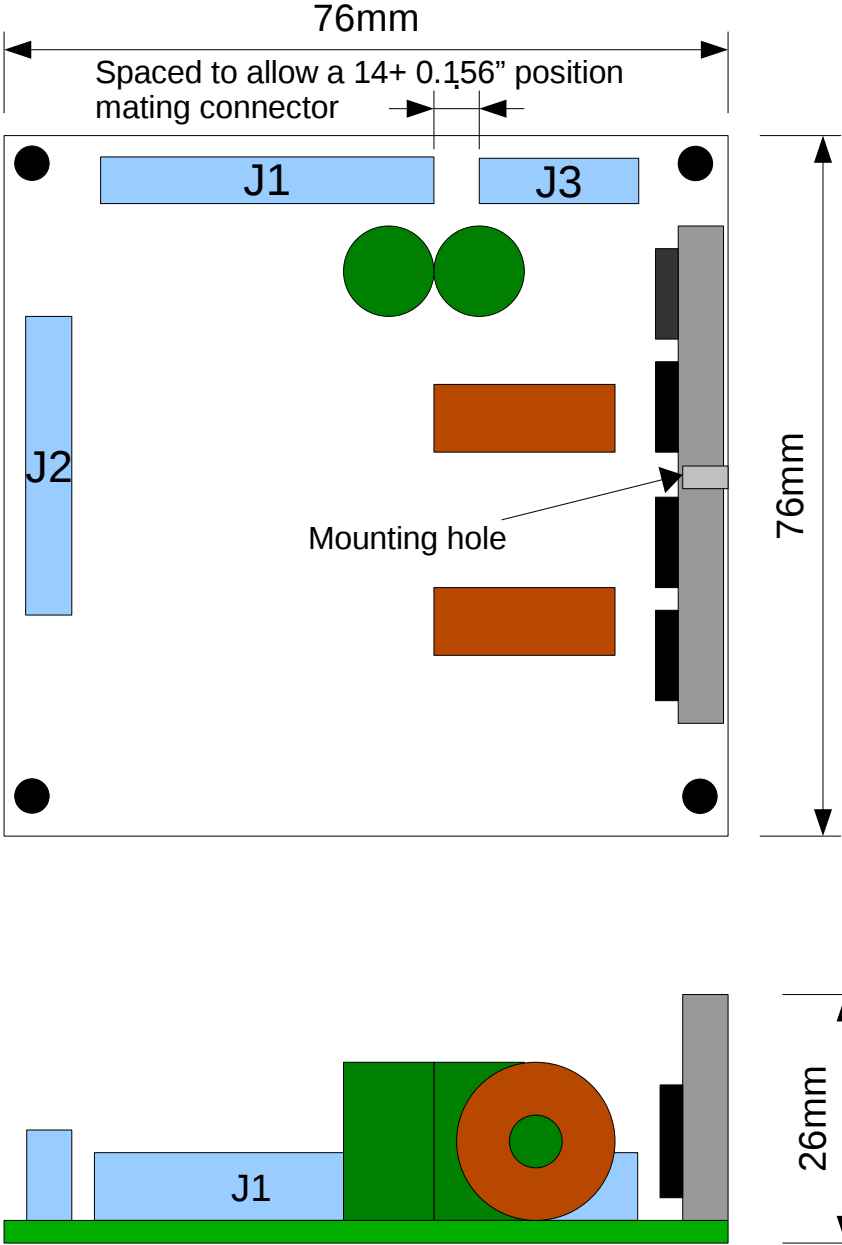

Figure 1: Amplifier Outline and Mounting Hole Locations

## A2-154 Amplifier specifications:

Unless otherwise specified, One channel driven,  $f = 1\text{kHz}$ ,  $R_L=4\Omega$ ,  $T_a=25\text{ }^\circ\text{C}$ ,  $V_b = +/- 44\text{V}$

| <i>Parameters</i>                    | <i>Symbols</i> | <i>Test Condition/ Comment</i>                                       | <i>Min</i> | <i>Typ</i> | <i>Max</i> | <i>Unit</i>     |
|--------------------------------------|----------------|--|------------|------------|------------|-----------------|
| Load Resistance                      | $R_L$          |  | 2.5        | -          | -          | $\Omega$        |
| Max Output Power                     | $P_{max}$      | $f=20\text{Hz}-20\text{kHz}$ (1% THD)                                |            | 160        | -          | W               |
| Ouput Power                          | $P_o$          | $f=20\text{Hz}-20\text{kHz}$ (0.1% THD)                              | -          | 150        | -          | W               |
| Max Bridged Output Power             | $P_{maxb}$     | 1% THD   |            | 500        |            | W               |
| Sensitivity                          | $V_{sen}$      | Input Signal to $P_o$  | -          | 3.5        | -          | $V_{rms}$       |
| Gain                                 | $A$            |  | 21         | 22         | 23         | dB              |
| Distortion                           | THD+N          | $10\text{Hz} < f < 20\text{kHz}$ ,<br>$100\text{mW} < P_{out} < P_o$ | -          | .03        | .05        | %               |
| Freq. Response                       | $f$            | 20Hz-20kHz   | -          | +/- 0.5    | -          | dB              |
| Noise Floor                          | $V_{NF}$       | Input Shorted, A-weighted  | -          | 25         | 35         | $\mu\text{V}$   |
| Maximum Current                      | $I_{max}$      |  | 18         | 20         | 25         | A               |
| Peak Current                         | $I_{pk}$       |  |            | 27         |            | A               |
| Damping Factor                       | DF             | $R_L = 4\text{ ohms @ } 100\text{ Hz}$                               | -          | 375        | -          | $\Omega/\Omega$ |
| Power Bandwidth                      | $BW_{pw}$      | Output Power: $P_{max}$  | -          | 60k        | -          | Hz              |
| Small Signal Bandwidth               | $BW_{sm}$      | Output Power: 1Watt  | -          | 90k        | -          | Hz              |
| Signal to Noise                      | SNR            |  | 117        | -          | -          | dB              |
| Turn on threshold for the +15v input | $V_{on\_15}$   | Above this level, the amp will start operating                       | -          | 10         | -          | V               |
| Startup Delay                        | $T_{start}$    | After +15v rises   | .5         | -          | 1.2        | Sec             |
| Bus Voltage                          | +/- $V_{bus}$  |  | +/-25      |            | +/-44      | V               |

## Performance Graphs:

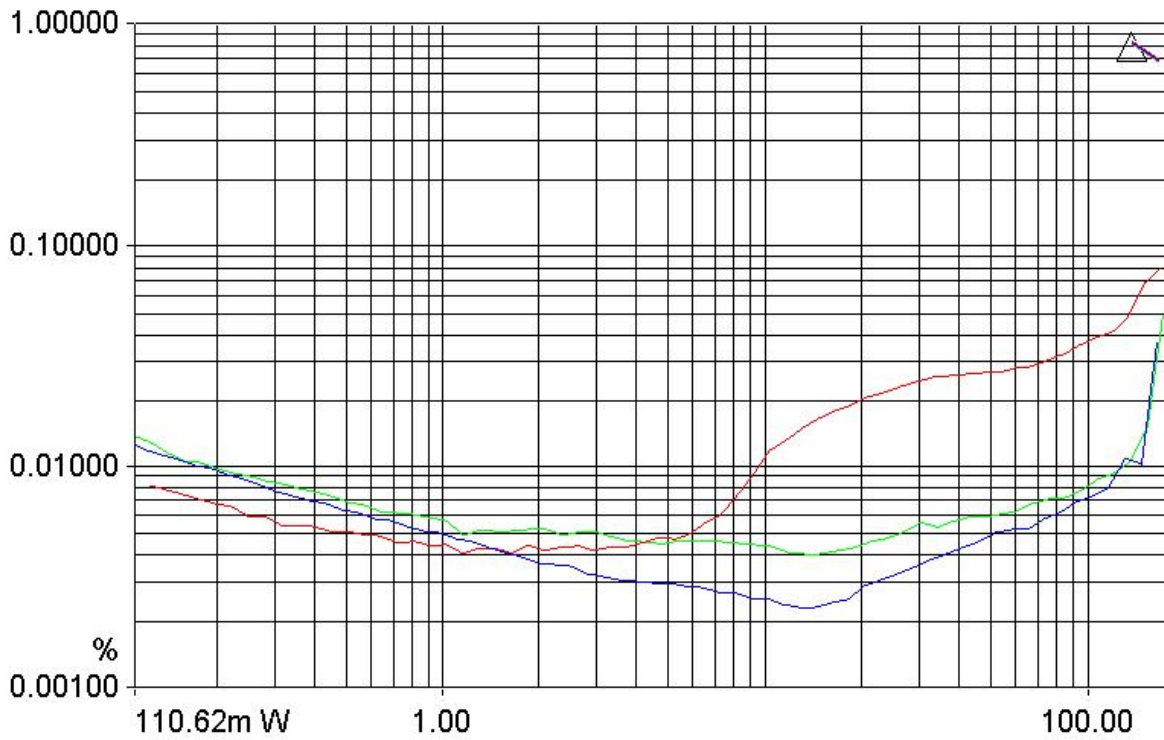

100Hz, 1kHz, 6.67kHz. AES17 Filter. 4 Ohm Load

**Figure 2: THD+N versus Power**

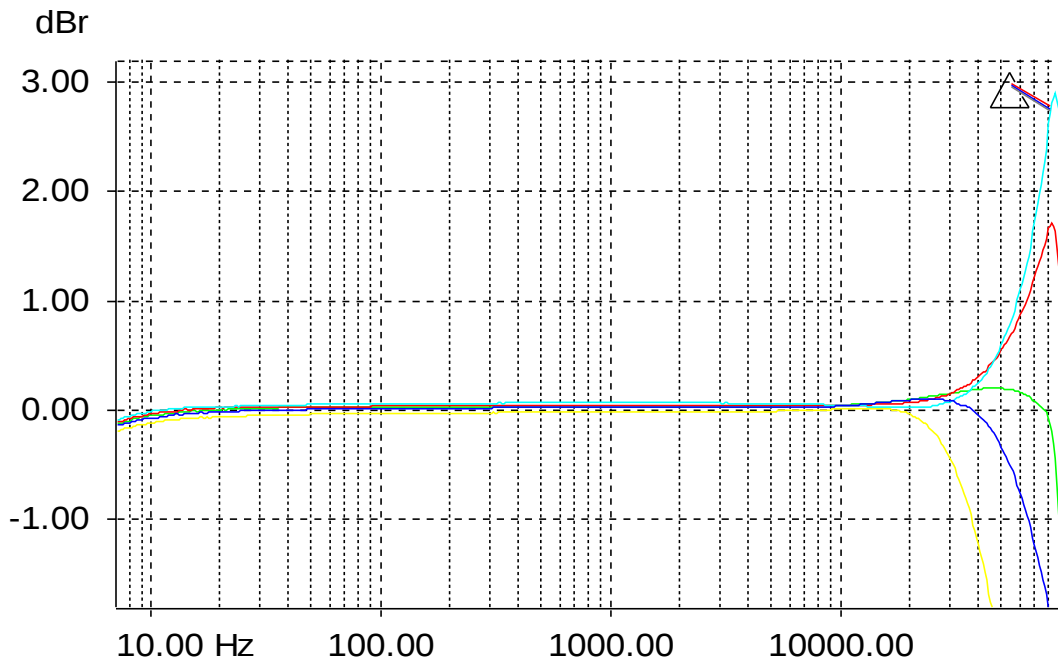

**Figure 3: Frequency Response**

*1.5ohm yellow, 2.25ohm blue, 4ohm green, 8ohm red, Open light blue. While stable at 1.5ohms, the recommended minimum load is 2.5ohms.*

## Connector pin out:

### Audio Interface Connector (J2)

Right angle or vertical header options:

1. **Right angle header no lock: 2x7 pin 0.1" Header. MOLEX 71764-0014**
2. (OPTIONAL) Vertical header with shroud: 2x7 pin .1" Header 3M 30314-6002HB

| Pin | SIGNAL        | DESCRIPTION   |
|-----|---------------|---|
| 1   | GND           |   |
| 2   | Audio A       | Channel A Audio Input   |
| 3   | Audio B       | Channel B Audio Input   |
| 4   | GND           |   |
| 5   | +15 OUT       |   |
| 6   | -15 OUT       |   |
| 7   | GND           |   |
| 8   | CURRENT MON A | Ch A Load Current Signal Monitor                                |
| 9   | CURRENT MON B | Ch B Load Current Signal Monitor                                |
| 10  | STATUS        | Amplifier Status Indicator                                      |
| 11  | DISABLE       | Amplifier Disable   |
| 12  | TEMP MONITOR  | Power MOSFET Temperature Monitor                                |
| 13  | SYNC          | Clock signal for synchronize amplifier clocks to a Master clock |
| 14  | GND           |   |

### Power Connector (J1)

Right angle or vertical header options:

1. **Vertical Header without Friction Lock: 1x8 pin 0.156" centers. no lock: AMP 640383-8**
2. (OPTIONAL) Right Angle Header w/out friction lock: 1x8 pin 0.156" centers, right angle post, no lock: Amp 640385-8.
3. (OPTIONAL) Vertical Header with friction lock: 1x8 pin 0.156" centers, friction lock: JST B8P-VH.

| Pin | SIGNAL    |
|-----|-----------|
| 1   | +40v      |
| 2   | -28v      |
| 3   | -40v      |
| 4   | POWER GND |
| 5   | POWER GND |
| 6   | +15v      |
| 7   | -15v      |
| 8   | AGND      |

## Speaker Output (J3)

Right angle or vertical header options:

1. **Vertical Header without Friction Lock: 1x8 pin 0.156" centers. no lock: AMP 640383-4**
2. (OPTIONAL) Right Angle Header w/out friction lock: 1x8 pin 0.156" centers, right angle post, no lock: Amp 640385-4
3. (OPTIONAL) Vertical Header with friction lock: 1x8 pin 0.156" centers, friction lock: JST B4P-VH

| Pin | SIGNAL |
|-----|--------|
| 1   | GND    |
| 2   | OUT A  |
| 3   | GND    |
| 4   | OUT B  |

## Power Supply Requirements:

| Voltage | Normal Op Current                      | Disable mode Current | Minimum | Maximum |
|---------|--|----------------------|---------|---------|
| +15v    | 95mA                                   | 0.15 ma              | +10v    | +15.5v  |
| -15v    | 50mA                                   | ~0 mA                | -15.5v  | -10v    |
| -28v*   | 65mA                                   | ~0 mA                | 10v     | 12v     |
| +40v    | 46mA @ idle<br>6.5A @ P <sub>max</sub> | ~0mA                 | +25     | +44     |
| -40v    | 53mA @ idle<br>6.5A @ P <sub>max</sub> | ~0mA                 | -25v    | -44     |

\* The -28v supply is referenced to the -40v supply

## Amplifier Operation:

### STATUS INDICATOR:

The amplifier STATUS pin is an active pull down signal that indicates when the amplifier is being placed in Protect Mode. This occurs during the following conditions:

1. For approximately 1 second after the +15v is applied to the module
2. When the amplifier is in temperature protection mode and is limiting the maximum output power.
3. When the amplifier has reached peak current detection and is shut down for approximately 1 second.
4. For approximately 1 second after the amplifier has been enabled after being disabled.

To sense this signal , an external 10k ohm pull up resistor to 5v is needed (see Figure 4).

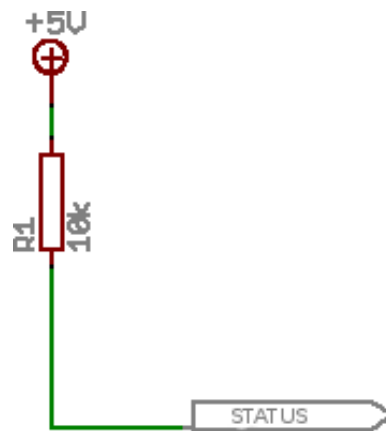

**Figure 4: Status Signal External Pull Resistor**

## **DISABLING THE AMPIIFIER:**

The amplifier can be disabled by pulling up the disable pin above 2.5v. This completely turns off the amplifier and drops the amplifier supply current, both the main power and bias power to zero amps. When this signal is released, the amplifier will turn on after a one second delay.

## **OVER CURRENT OPERATION:**

If the amplifier has both an over current clamp limit ( $I_{max}$ ) and a peak current limit ( $I_{pk}$ ). The amplifier will limit the maximum current to the  $I_{max}$  level. This is designed for lower impedance loads (< 2.5 ohms). However, for directly shorted speaker loads where response time is critical, the peak current limit may trip. If this trips, the amplifier will shut down for approximately 1 second before retrying. During the shut down, the STATUS pin will be in the Protect mode.

## **CURRENT MONITORING OPERATION:**

The real time output current of each amplifier can be monitored by the CURRENT MON pin. The voltage on the CURRENT MON pin represents the output current by the following equation:

$$V_{currentmonitor} = 0.163I_{out}$$

The voltage on the CURRENT MON pin is a differential signal (+3.5 to -3.5v max range). A current monitor voltage above |3.25v| signifies the over current limit threshold. There is also a small amount of switching frequency noise on this signal ( $F_{s_{noise}}$ ). The CURRENT MONITOR pin is directly connected to the amplifier current monitoring circuitry. Any sensing of this pin must be with high input impedance (> 50k) or the current monitoring and current limit levels will be affected.

## **AMPLIFIER STARTUP POWER SEQUENCE:**

The amplifier will start operation 1 Sec after the +15v supply rises above 10v and the bus voltages (i.e. +/-40v) are above 15v. It is assumed that the -15v supply magnitude will match the +15v supply during this startup.

## TEMPERATURE PROTECTION AND MONITORING:

Temperature protection will NOT turn off the amplifier, it will still play when over 100% thermal capacity. During this over temperature mode high output power peaks will be limited. Limiting will continue until the temperature drops below 100%.

The A2-154 TEMP MONITOR on the AUDIO INTERFACE outputs the combined power MOSFET temperatures of both amplifier channels. Figure 5 below plots the TEMP MONITOR output voltage versus thermal capacity. The amplifier will go into PROTECT mode and limit the amplifiers output power if the sensed temperature goes above 100%.

NOTE: The TEMP MONITOR pin is directly connected to the amplifier thermistor circuitry. High in input impedance (> 100k Ohms) sense circuitry is required, or the temperature monitoring circuit will be affected.

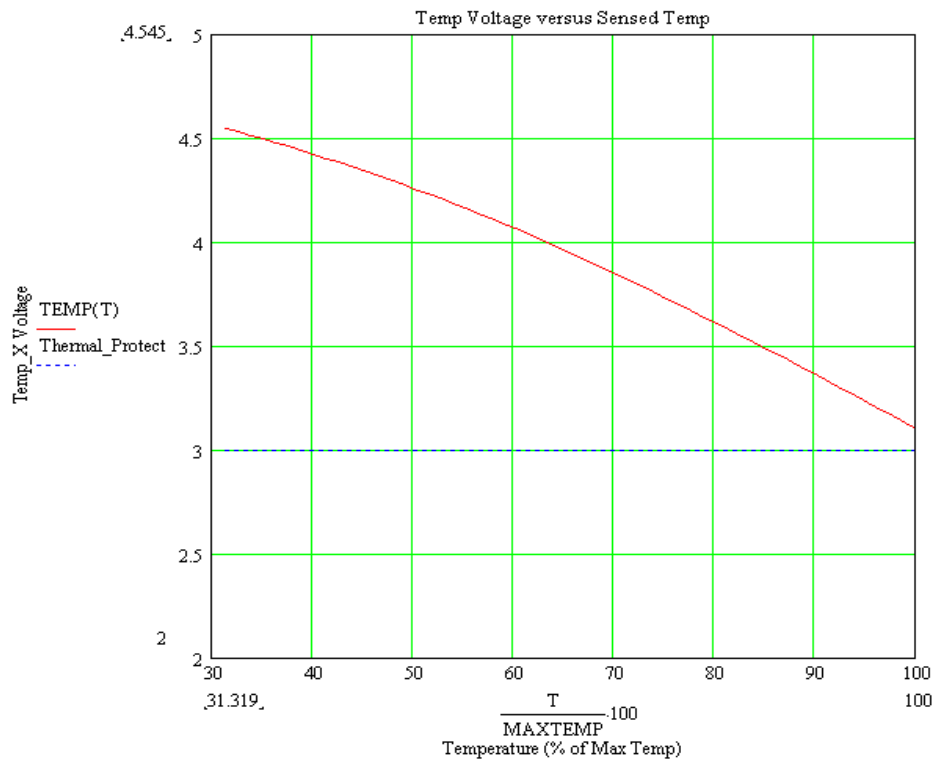

Figure 5: Voltage versus maximum operating temperature

## **SYNCHRONIZED CLOCK FREQUENCIES:**

The amplifier switching frequency clocks are synchronized to each other to avoid heterodyne noise in the audio band. In addition, an external 425kHz-440kHz sync signal can be supplied on the SYNC pin that will synchronize the clocks to an external source.