

Features:

- Proprietary One-Cycle Sound™ Control
- 117dBA dynamic Range
- THD+N < 0.05%, 0.1W – Rated Power
- Full range 20 to 20kHz Bandwidth
- Efficiency > 90%
- Damping Factor > 100 @ 50Hz 2.5Ohm
- DC offset < 25mV
- Remote Disable
- Over Current Protection to Speaker Short and short to Chassis Ground
- Temperature Protection and Monitor
- Protect, Clip and Signal Present Indicators
- Power Supply Under Voltage Lockout
- Power On Self Test POST
- Compatible with P-1000-120 Power Supply
- Dimensions:
 - inches: 3.8 x 4.05 x 1.0
 - mm: 96 x 103 x 23

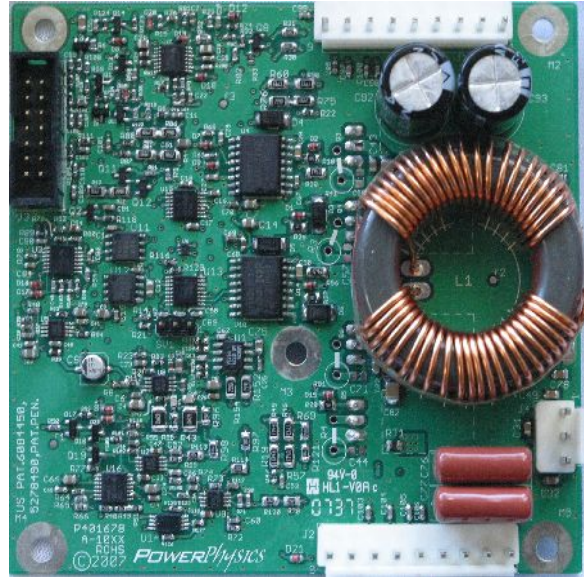

Product Description: New for 2008!

PowerPhysics is proud to announce the A-1014 full range 1000W amplifier for 4 Ohm loads. The A-1014 uses a 120V bus to drive 1000 Watts into an 4 Ohm speaker. New in the A-1014 are: output feedback to lower the noise floor and reduce sensitivity to load impedance; over-current protection to speaker fault and chassis ground; current monitor signal. Another demonstration of PowerPhysics' commitment to continuous improvement.

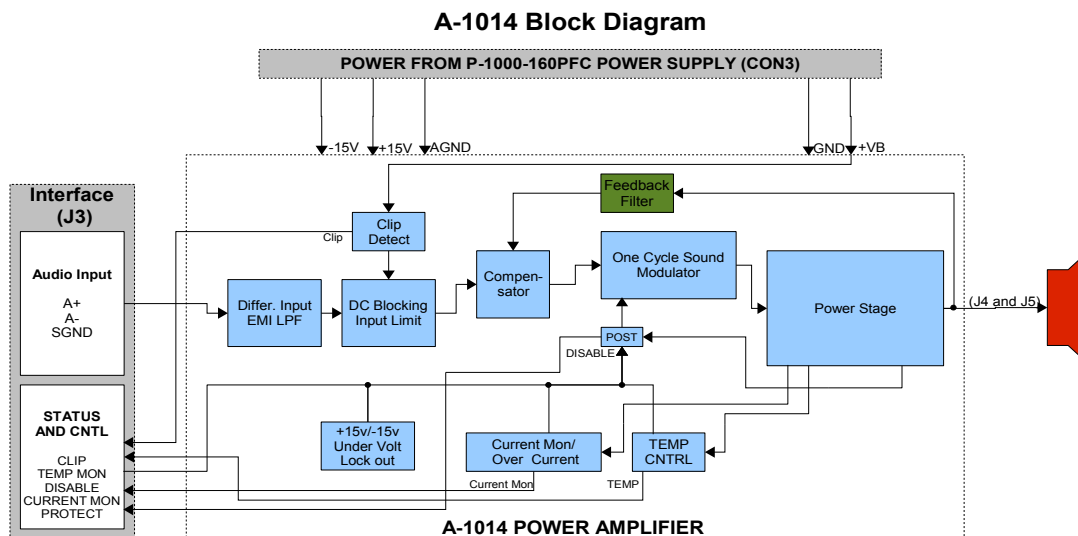

Total Harmonic Distortion - 4 Ohm load

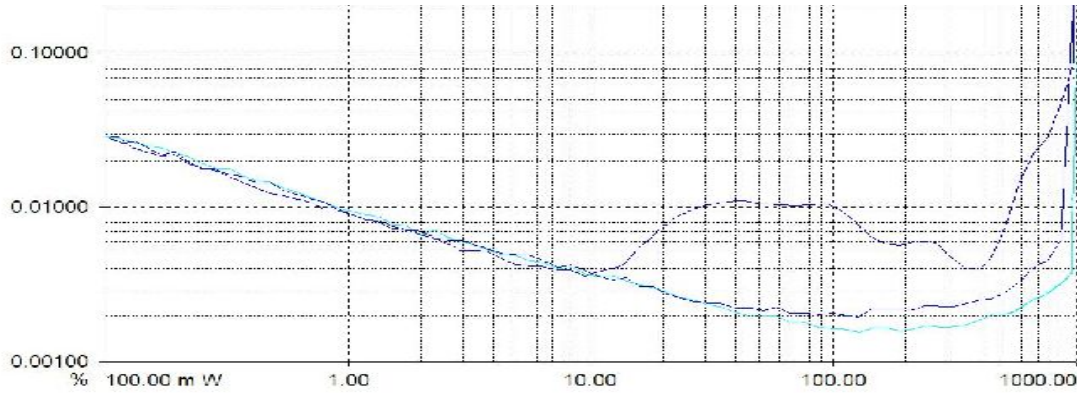

Noise Floor with 100mW 1kHz Signal

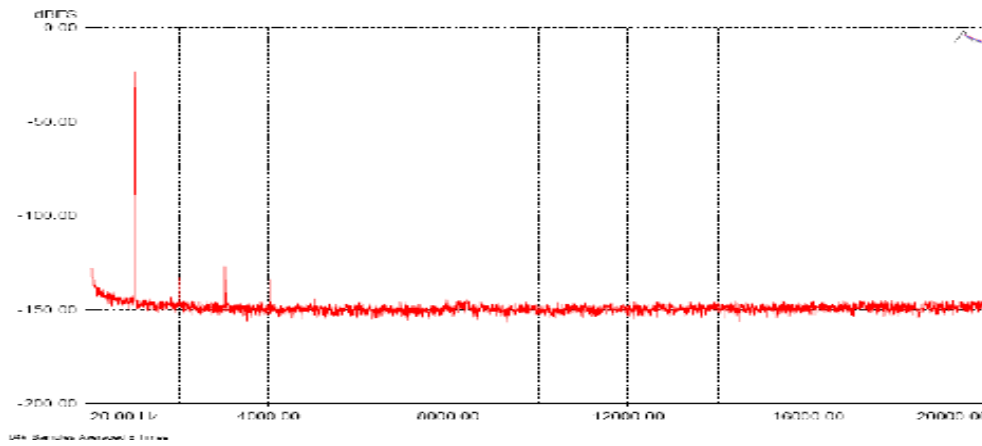

Frequency Response - Green 8 Ohm, Red 4 Ohm, Blue Open

